

**SONY**<sup>®</sup>

**CINE ALTA**<sup>™</sup>

**HDCAM SR**<sup>™</sup>



HD Digital Videocassette Recorder  
**SRW-5000/5500**



## CineAlta™ — Liberating Movie Makers

CineAlta – a name that proudly symbolizes the bond between cinematography and Digital high-definition imaging. It distinguishes a Sony family of products and systems that offer new levels of creativity in the production, postproduction, and exchange of motion pictures. It also brings together the quality and universality of 24-frame cinematography with the real-time capabilities, efficiency, and flexibility of Digital high-definition technology. And it stimulates the convergence of Motion Picture Film and Digital high-definition production on a global basis.

CineAlta products, delivering cinema-quality pictures at selectable frame rates, are simplifying International Program Exchange by minimizing the need for standards conversion. They are also opening up entirely new possibilities for international co-production. Movie making has been liberated by the creative empowerment of the cinematographer. It is facilitated by real-time HD image evaluation on-set, instant replay of full-color high-resolution digital “takes,” real-time image optimization while shooting, a 50-minute shooting load, and most importantly, by the significant cost-benefits associated with this digital medium.

CineAlta products provide a seamless bridge between 24-frame film originals and a final 24P digital master, giving each frame of film a one-to-one correspondence with progressive HD frames. The CineAlta environment readily interfaces with the computer graphics world, liberating postproduction. And the final liberation is achieved through the direct color conversion of progressive 24P masters to film, and to a host of other international digital HDTV and SDTV distribution formats.

# Apex In High-Resolution Storage

The arrival of the HDCAM™ format heralded a new era in movie-making, commercial production, and high-end television production applications. A dramatic breakthrough in this field was achieved with the Sony multi-frame rate camcorder, the HDW-F900, and its companion VTR the HDW-F500. Both products bore the CineAlta™ name – signifying system elements that uniquely explore new horizons in these application areas.

CineAlta products are Sony's response and commitment to the ITU 709 global standard, specifically intended for international high-definition (HD) program origination. Globally, HD programming is becoming far more mainstream, and the HDCAM format has become the most popular format supporting it. The popularity has escalated demand for even higher quality and greater storage capacity – enough to support extremely high-quality digital production, high-resolution film transfer work, sophisticated graphics recording, and multi-channel audio mastering.

Responding to the requests for more headroom in digital recordings by many prominent content producers, Sony has introduced a new state-of-the-art format that provides a platform enabling greater storage capacity, higher data-transfer rates, and more audio channels than current HDCAM models. This new format is HDCAM-SR™ format. The HDCAM-SR format has a capacity several times greater than conventional tape formats, and it has been conceived from the very beginning as a format suitable for pristine-quality digital field acquisition.

Built on this HDCAM-SR infrastructure, Sony offers two models that expand the CineAlta product line – the SRW-5000

HD Digital Videocassette Recorder, exclusive for HDCAM-SR recording, and the SRW-5500 which additionally offers HDCAM recording. Like the CineAlta flagship HDW-F500, these VTRs acquire each picture frame according to the industry-standard Common Image Format (CIF), which specifies a sampling structure of 1920 x 1080 active pixels (H x V). The SRW-5000 and SRW-5500 therefore fit perfectly into existing workflows, and as full-fledged studio machines, they incorporate all of the editing capabilities and features that production teams demand for the execution of their products.

In their standard configurations, these VTRs record in the 4:2:2 format, which can be combined with current HDC series studio cameras to form a system that is ideal for high-end studio/OB production applications. With an optional RGB processor board installed, they can also be combined with their counterpart camera, the HDC-F950, to form a full-bandwidth 4:4:4 (RGB) image capturing-system. What's more, the SRW-5000 and SRW-5500 support multi-frame-rate recoding on the all-new HDCAM SR format, and deliver a host of invaluable features such as integrated up-conversion, down-conversion, 2-3 pull-down, and legacy playback of HDCAM and Digital Betacam™ tapes. And for today's digital content mastering applications and for future content delivery methods, they come with 12 channels of digital sound.

Such creative benefits along with the system's functionality, flexibility, durability, and maintainability will alleviate total cost of ownership concerns. The SRW-5000 and SRW-5500 are assets today, and will remain so into the future.



SRW-5000

SRW-5500

# Features and Benefits

## HDCAM-SR Format Recording

### 1080 Recording and Playback

The SRW-5000/5500 records full HD images at an exceptionally high picture quality using 1080 x 1920 active pixels as specified by the ITU Common Image Format (CIF). The entire range of both interlaced and progressive frame rates are available, ranging from 24/25P progressive imaging, to 50/60i for high-end HDTV production applications.

The SRW-5000 records top-quality 4:2:2 Y/Pb/Pr component or full-bandwidth 4:4:4 (RGB) 10-bit recordings\*, both with very mild compression.

The SRW-5000/5500 also offers up to 12 channels of 24-bit audio at 48 kHz, to meet the needs of the most demanding audio recording requirements in digital-content mastering. Each channel is independently editable.

The SRW-5000/5500 is the optimal VTR for any movie-making task – from acquisition and editing to telecine transfers and digital mastering.

\*Requires the optional HKSR-5003 RGB Processor Board.

### 720P Recording and Playback

In standard configuration, the SRW-5000/5500 also records in 4:2:2 720/59.94P or 720/50P formats. These formats can be used for DTV programming and transmission applications.

As with the 1080 format, you still have up to 12 channels of independently editable 24-bit audio available when operating in 720P format. In addition, 720P/1080i and 720P/480i bi-directional format conversion can be accomplished in this VTR.

### HDCAM-Format\* Recording (SRW-5500 only)

In addition to the HDCAM-SR format, the SRW-5500 enables HDCAM recording and playback in all frame rates specified by the format, including 1080/23.98, 24, 25, 29.97, 30P/F and 1080/50, 59.94, 60i. It supports full editing capability of HDCAM format recordings including independent editing of the four audio channels.

This HDCAM recording capability offers a cost-effective yet high quality alternative, operating in the full quality of the industry-standard Common Image Format (CIF).

\*The HDCAM format does not support 720P recording.

### Internal Format Conversion

The SRW-5000/5500 is equipped with an internal down converter that provides SDTV outputs from 1080 recordings. By adding optional plug-in boards, you can give the SRW-5000/5500 extended format-conversion capabilities such as 2-3 pull-down capability, up/down conversion from 720P recordings, and 4:4:4 to 4:2:2 conversion. Refer to the format-conversion chart on page 8 for further details.

## Legacy Playback

Not only is the SRW-5000/5500 an affordable VTR for use in digital cinematography and high-end HD production, it also provides a smooth migration path for organizations with legacy systems by retaining current acquisition tools and archives in action. The SRW-5000/5500 can play back HDCAM and Digital BETACAM\* tapes, making it an ideal and cost-effective solution for facilities involved in demanding high-end film and HD work.

\*Requires the optional HKSR-5002 Digital BETACAM Processor Board.

## Long Recording Time on a Single Cassette

Utilizing the technologically advanced HDCAM-SR format's high-density recording capability and compression technology, the SRW-5000/5500 is capable of recording up to 155 minutes at 1080/24PsF and up to 124 minutes at 1080/59.94i or 720/59.94P on a single L-sized cassette. S-sized cassettes can also be used, offering up to 50 minutes of recorded material at 1080/24PsF and up to 40 minutes of 1080/59.94i or 720/59.94P.

This flexibility makes the SRW-5000/5500 an ideal recorder for both field and studio applications.

\*When the SRW-5500 records in the HDCAM format, it provides the same recording times as the HDCAM-SR format.



## Easy Maintenance

Drum maintenance is always a concern for VTR users. As with most Sony VTRs, the SRW-5000/5500 drum assembly has been designed with an auto-adjustment function, so that maintenance can be performed in minimal time.

## User-friendly Controls

The front control panel of the SRW-5000/5500 is extremely user friendly, with a design and functionality, inherited from the widely used HDW-F500. In addition, the control panel has a large 6.4-inch\* type LCD display that provides comprehensive information, including color thumbnails, for quick location of parameters, which is used in combination with eight menu buttons placed along the side of the display.

\*Viewable area measured diagonally.



SRW-5000

# Operational Features



## Frame-Accurate Insert/Assemble Editing

The SRW-5000/5500 recorder is capable of insert or assemble editing with frame accuracy. Each channel of video and audio is independently editable. Executing precise editing on HDCAM-SR or HDCAM\* tapes in machine-to-machine or A/B roll configurations is possible.

\*SRW-5500 only

## High-Speed Color Picture Search

Recognizable color pictures are provided in shuttle mode at speeds up to 42 times normal playback for the HDCAM-SR format, and at speeds up to 50 times normal playback for HDCAM and Digital BETACAM formats.

## Dynamic Tracking™ Playback

A Dynamic Tracking playback capability provides high-quality pictures over the range of  $-1$  to  $+2$  times normal playback speed during the playback of HDCAM-SR and HDCAM tapes, and  $-1$  to  $+3$  for Digital BETACAM tapes.

## Digital-Jog Sound

In Jog mode, all 12 audio digital channels of the HDCAM-SR format or all four channels of the HDCAM format can be reproduced with a responsiveness and sound quality reminiscent of analog audio. This feature is essential to quickly and precisely establish an editing point while monitoring the digital audio signals, which remain synchronized with the pictures.

## Dynamic Motion Control (DMC) Playback

The SRW-5000/5500 also provides a DMC playback capability, memorizing the tape-speed trajectory over the dynamic tracking-speed range ( $-1$  to  $+2$  times normal speed).

## Pre-Read Editing

The SRW-5000/5500 is equipped with advanced playback heads that allow pre-read editing, making functions such as titling with a single VTR and A/B-roll editing with two VTRs possible.

## Confidence Playback

Separate dedicated playback heads immediately follow the recording heads so that actual audio and video recorded to the tape can be monitored while recording. Confidence playback can be used to verify the quality of a recording without interrupting production. This feature can also be used while pre-read editing to verify that the edit has been properly performed to tape.

## Selectable Picture Modes

Three modes of operation – SQUEEZE, LETTER BOX, and EDGE CROP – are available to provide the correct presentation for the application type.

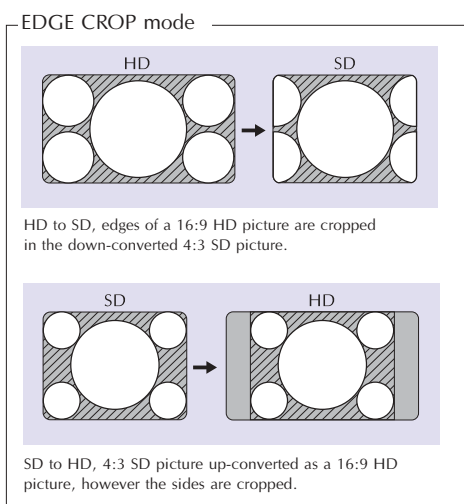
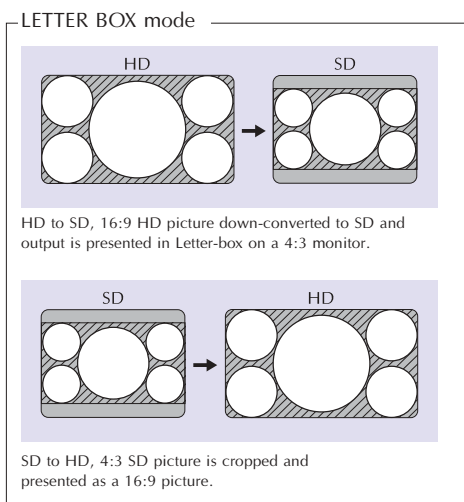
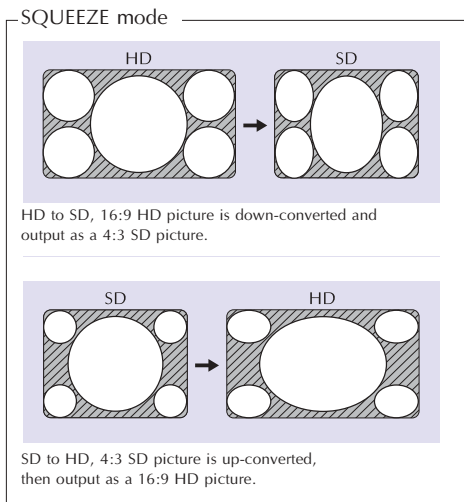

## Audio-Output Channel Selection

The SRW-5000/5500 is equipped with a unique internal audio-output router, which enables flexible audio-output channel routing without the use of an external audio-routing device. Any channel from the 12\* available on HDCAM-SR tape can be assigned to the HD-SDI (Ch 1-12) and SDI (Ch 1-8) embedded audio-output channels. This feature provides the flexibility needed when recording audio to different tape formats.

\*Four channels on HDCAM tape

## Dual-Sync Operation

A unique feature of the SRW-5000/5500 allows you to seamlessly integrate the VTR into a 59.94 editing environment. In doing so, you can directly perform insert editing from a 23.98PsF master tape, either to a 1080/59.94i or to a 525/59.94i recording, without having to first dub the master to the 59.94 format. This is achieved by supplying dual reference signals, one to lock the servo of the SRW-5000/5500 to a 23.98Hz signal and one to lock the playout circuitry to a 59.94Hz reference signal.

## Off-Speed Playback Capability

In order to play back material at different speeds for applications such as slow-motion or fast-motion, the SRW-5000/5500 is equipped with a built-in off-speed playback capability.

- Normal playback
- 0.1% off-speed playback
- ▲ Video and audio off-speed playback with converted timecode (requires audio pitch correction)
- ◆ HDCAM-SR: Video and audio off-speed playback (requires audio pitch correction)
- ◇ HDCAM: Video off-speed playback (without audio)

Machine Setup	HD-SDI output					
	1080					720
	23.98PsF	24PsF	25PsF /50i*	29.97PsF /59.94i*	30PsF /60i*	
1080	23.98PsF	○	●	▲	◆	◇
24PsF	●	○	▲	◆	◇	
25PsF/50i*	▲	▲	○	◆	◇	
29.97PsF/59.94i*	◆	◆	◆	○	●	
30PsF/60i*	◆	◆	◆	●	○	
720	59.94P**					○

\* When scanning modes (interlace or PsF) of the VTR setup and playback tape are different, the output signal is provided in the playback tape's scanning mode.

\*\* HDCAM-SR only

## Easy Setup Using "Memory Stick™" Media

Equipped with a Memory Stick\* slot inside its front panel, the SRW-5000/5500 allows VTR setup files to be saved onto and recalled from a "Memory Stick" media. These files can later be copied onto other SRW-5000/5500 machines, enabling quick and consistent setup of multiple VTRs. A group of parameters can be named by the operator as desired to provide further enhanced setup operation.

\*"Memory Stick" is optional.

## Internal Format-Conversion Capability

REC/PLAY Tape Format			HD-SDI OUT		SD-SDI OUT	HD-SDI (format conv. out) (requires optional HKSR-5001)
HDCAM-SR	1080/4:4:4**	23.98PsF	1080/4:4:4	23.98PsF	—	1080/4:2:2/23.98PsF
		24PsF		24PsF	525/59.94i*	1080/4:2:2/59.94i
		25PsF		25PsF	—	720/4:2:2/59.94P
		29.97PsF		29.97PsF	—	1080/4:2:2/24PsF
		30PsF		30PsF	625/50i*	1080/4:2:2/60i
		50i		50i	525/50i*	1080/4:2:2/25PsF
		59.94i		59.94i	525/59.94i*	720/4:2:2/50P
	60i	60i	—	1080/4:2:2/29.97PsF		
	50P	50P	625/50i	1080/4:2:2/30PsF		
	59.94P	59.94P	525/59.94i	1080/4:2:2/50i		
HDCAM or HDCAM-SR	1080/4:2:2	23.98PsF	1080/4:2:2	23.98PsF	525/59.94i*	720/4:2:2/59.94i
		24PsF		24PsF	—	1080/4:2:2/59.94P
		25PsF		25PsF	—	1080/4:2:2/60i
		29.97PsF		29.97PsF	625/50i	720/4:2:2/50P
		30PsF		30PsF	525/59.94i	720/4:2:2/59.94P
		50i		50i	—	—
		59.94i		59.94i	625/50i	720/4:2:2/50P
	60i	60i	525/59.94i	720/4:2:2/59.94P		
	59.94i	59.94i	—	—		
	60i	60i	525/59.94i	—		
Digital BETACAM***	625	50i	1080/4:2:2	50i	625/50i	720/4:2:2/50P
		59.94i	720/4:2:2	50P	—	1080/4:2:2/50i
	525	59.94i	1080/4:2:2	59.94i	—	720/4:2:2/59.94P
		60i	720/4:2:2	59.94P	525/59.94i	1080/4:2:2/59.94i

\*Requires optional HKSR-5001 Format Converter Board

\*\*Requires optional HKSR-5003 RGB Processor Board

\*\*\*Requires optional HKSR-5002 Digital Betacam Processor Board

## Versatile Interfaces

The SRW-5000/5500 features a wide range of interfaces including:

- HD-SDI I/O
- HD-SDI (format conversion) out
- SDI out
- SD composite out
- AES/EBU digital audio I/O
- Analog audio out
- Analog audio in(cue)\*
- Ethernet port
- RS-232/422 50-pin control interfaces
- Video control

\*SRW-5500 only



SRW-5500 Rear Panel

# HDCAM-SR Technology

The HDCAM-SR format is based on cutting-edge technology. It is not a rehashed and repackaged technology solution developed in previous decades. The HDCAM-SR format has been designed to maximize the data-transfer rate without sacrificing any operational features. It's a design you'd expect from a Sony 1/2" tape format, with all the useful playback and editing features common to existing Sony tape formats. And although the SRW-5000/5500 features and capabilities have seen great improvements, the physical size and power consumption of the VTR remain modest enough to achieve easy portability for field use. And, in order to meet the format's mission-critical requirements, every aspect of magnetic tape-recording engineering and digital-signal processing technology has been carefully reassessed and integrated. Even with these great technological improvements, the expected operating costs of this system are reasonable.

## Creating Virtually Lossless Images: The MPEG-4 Studio Profile (SP)

Yet another industry first from Sony is an integrated video encoding/decoding chipset that conforms to the MPEG-4 SP (Studio Profile: ISO/IEC 14496-2:2001-1). The Studio Profile was created to specifically address the requirements of high-resolution image-production applications. It is free from GOP (Group Of Pictures) structures, and is scalable in its pixel count (SDTV, HDTV, Film-resolution data), bit depth (10- or 12-bit), and color resolution (component or RGB). In order to achieve maximum compression efficiency, the HDCAM-SR format resorts to intra-frame compression for progressive images. Intra-field compression is used for interlaced images. Special attention has been paid to multi-generation dubbing performance and, in common with industry-standard Digital BETACAM VTRs, the SRW-5000 is capable of consistent dubbing without using a separate interface for a native stream. This is only possible thanks to the high performance of the MPEG-4 SP, which offers reproduction of virtually lossless images.

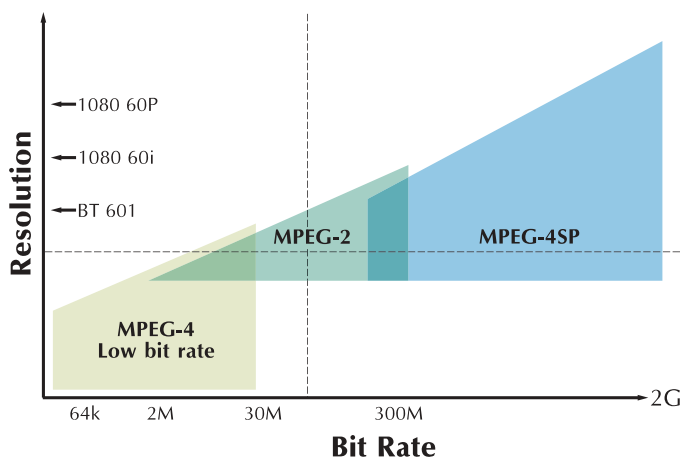

## More Data, Same Long Running Time: The New Footprint

Each picture frame consists of 24 helical tracks (or 12 tracks per segment/field), in which data is shuffled to protect the recording from occasional burst errors. Recordings are further protected by highly robust error-correction and concealment techniques perfected through years of Sony digital-VTR development. Thanks to the finer track pitch and shorter minimum recording wavelength, the data-packing density of the HDCAM-SR format is 3.5 times that of the HDCAM format. Frame-accurate editing is guaranteed by the intelligent allocation of pilot signals for precise head-to-tape tracking.

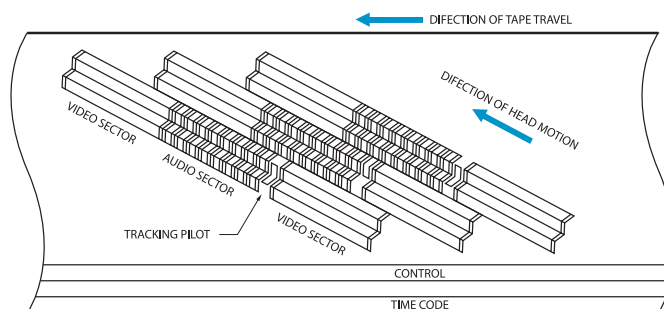

### Retaining The Virtues Of Sony 1/2" Formats: The New Drum Assembly

The new drum assembly has 8 channels each of recording and confidence-playback heads, plus a pair of flying-erase heads. As with all recent Sony high-end VTRs, the SRW-5000/5500 uses DT heads for normal playback as well as variable speed and jog playback. Precise tracking of the HDCAM-SR format tape is reliably secured by utilizing the newly designed 4-tip, 8-gap DT head assembly. Each tip has two gaps, which are slightly offset from each other. During playback, both gaps simultaneously trace the same video track. The off-tape data from the gap that produces a higher output signal is used for the actual image playback. In comparison to conventional systems, this unique mechanism allows a wider tolerance in head-to-track tracing. A dedicated pair of DT head assemblies performs legacy playback of HDCAM and Digital BETACAM tapes. Remarkably, despite the complexity of this new recording drum, durability and lifetime are expected to be equal to that of existing Sony 1/2" tape formats.

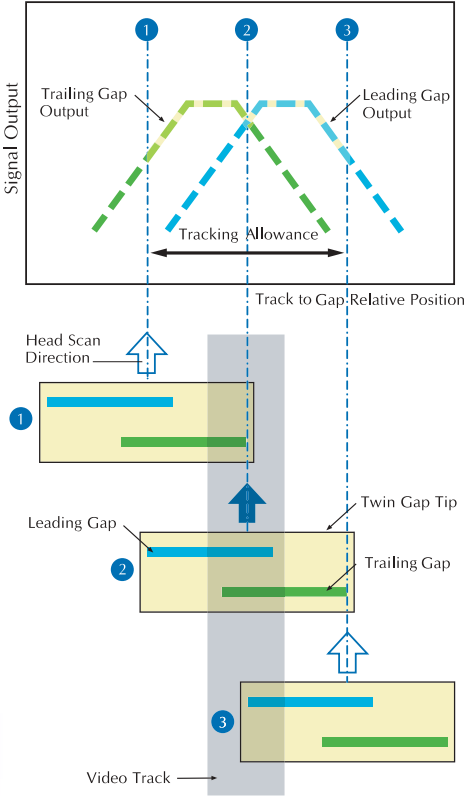
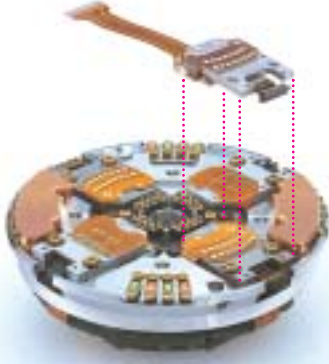
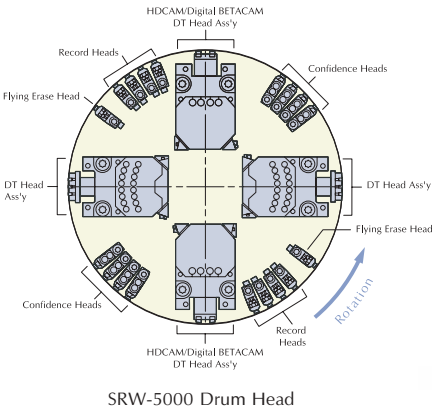

### More Power, More Stability: The New Tape Formula

A newly developed, ultra-fine-grain magnetic particle used on an HDCAM-SR tape creates the very thin magnetic layer required to achieve the minimum recording wavelength of  $0.29\mu$ . This minimum wavelength allows the tape to hold more data and increases the tape transfer rate, resulting in increased performance. Not only that, but stable and consistent playback results are provided through a new proprietary manufacturing process that minimizes tape deformation. What's more, because the tape medium is designed with a highly rigid new base film material treated with antioxidants, the HDCAM-SR tape is also ideal for archiving purposes.

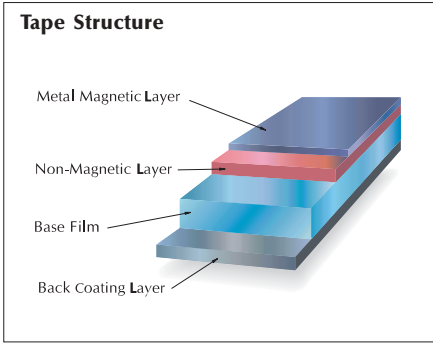

# SRW-5000/5500 Specifications

	SRW-5000	SRW-5500
<b>General</b>		
Power requirements	100 to 240 V AC (±10%, 50/60 Hz)	
Power consumption	230 W (without options)/320 W (with all option boards installed)	
Operating temperature	+5 °C to +40 °C (+41 °F to +104 °F)	
Storage temperature	-20 °C to +60 °C (-4 °F to +140 °F)	
Operating humidity	25% to 80% (relative humidity)	
Mass (approx.)	30 kg (66 lb 2 oz)	
Dimensions (W x H x D excluding protrusions)	427 x 218 x 544 mm (16 3/4 x 8 5/8 x 21 1/2 inches)	
Tape speed	HDCAM-SR: 94.2 mm/s (24 Hz) HDCAM: 77.4 mm/s (24 Hz) Digital Betacam: 96.7 mm/s	
HDCAM-SR/HDCAM* recording/ Playback time	155 min with BCT-124SR cassette (24 Hz) with BCT-124SRL or BCT-124HDL tape	
Digital Betacam playback time	124 minutes with BCT-D124L tape	
Fast-forward/rewind time	Approx. 4 min with BCT-124SR cassette	
Search speed range	Shuttle mode	HDCAM-SR: Still to ±50 times normal playback speed (24 Hz) HDCAM: Still to ±58 times normal playback speed (25 Hz) Digital Betacam: Still to ±50 times normal playback speed
	Variable mode	HDCAM-SR: -1 to 2 times normal playback speed HDCAM: -1 to 2 times normal playback speed Digital Betacam: -1 to 3 times normal playback speed
	Jog Mode	HDCAM-SR: Still to ±2 times normal playback speed HDCAM: Still to ±3 times normal playback speed Digital Betacam: Still to ±3 times normal playback speed
Dynamic Tracking Range	-1 to +2 times normal playback speed	
Servo-lock time	1.0 sec or less (from standby on)	
Load/unload time	7.0 sec or less	
<b>Input/Output</b>		
HD-SDI input A	BNC (1 + 1 for monitoring loop-through), Serial digital (1.485 Gb/s), SMPTE 292M/BTA S-004/ITU-R.BT 709	
HD-SDI input B (optional HKSR-5003 required)	BNC (1 + 1 for monitoring loop-through), Serial digital (1.485 Gb/s), SMPTE 292M/BTA S-004/ITU-R.BT 709	
HD/SD reference video input 1	BNC (1 + 1 for loop-through), Tri Level sync, 0.6 Vp-p, 75 Ω, sync negative or Black Burst, 0.286 Vp-p, 75 Ω, sync negative	
HD/SD reference video input 2 (optional HKSR-5001 required)	BNC (1 + 1 for loop-through), Tri Level sync, 0.6 Vp-p, 75 Ω, sync negative or Black Burst, 0.286 Vp-p, 75 Ω, sync negative	
Digital-audio input (CH1/2, CH3/4, CH5/6, CH7/8, CH9/10, CH11/12)	BNC (x6, AES/EBU), unbalanced	
Analog audio input (Cue)	—	XLR-3-pin, female x1
Time-code input	XLR-3-pin type, (female x1), 0.5 to 18 Vp-p, 10 kΩ, balanced	
HD-SDI output	BNC (x3, with character out), Serial digital (1.485 Gb/s), SMPTE 292M/BTA S004/ITU-R.BT 709	
Format-converter output (optional HKSR-5001 required)	BNC (x2), with character out	
SD-SDI output	BNC (2 + 1 with character out), D1 serial digital (270 Mb/s), SMPTE 259M	
Analog down-converted output	Composite: BNC (x1 with character out) 1.0 Vp-p, 75 Ω, sync negative) SD sync: BNC (x1, Black Burst, 0.286 Vp-p, 75 Ω, sync negative)	
Analog reference output	1125 Sync: BNC (x2), Tri Level sync, 0.6 Vp-p, 75 Ω, sync negative	
Digital-audio output (CH1/2 CH3/4 CH5/6 CH7/8 CH9/10 CH11/12)	BNC (x6), AES/EBU, unbalanced	
Analog-audio output (CH1/2/3/4/Cue**)	XLR-3-pin type, (male x5), +4 dBm, (with a 600 Ω load), low impedance, balanced	
Monitor output (L/R)	XLR-3-pin type, (male x2), +4 dBm, (with a 600 Ω load), low impedance, balanced	
Time-code output	XLR-3-pin type, (male x1), 2.2 Vp-p low impedance, balanced	
Phones	JM-60 stereo phone jack, ∞ to 12 dBu (with an 8 Ω load), unbalanced	
Remote 1 input	D-sub 9-pin, (female), Sony 9-pin remote interface	
Remote 1 input/output	D-sub 9-pin, (female), Sony 9-pin remote interface	
Video control	D-sub 9-pin, (female), (for optional HKDV-900)	
Parallel remote	D-sub 50-pin, (female)	
Ethernet	10Base-T modular jack	
<b>Digital-Video Performance</b>		
Sampling frequency	HDCAM-SR: Y: 74.25 MHz, Pb/Pr: 37.125 MHz, G/B/R: 74.25 MHz HDCAM*: Y: 74.25 MHz, Pb/Pr: 37.125 MHz	
Quantization	10 bits/sample	
Compression	HDCAM-SR: MPEG-4 Studio Profile HDCAM*: Coefficient Recording System	
Channel coding	S-NRZ	
Error correction	Reed-Solomon code	
Error concealment	Adaptive three-dimensional	
<b>Analog Composite-Output Performance</b>		
Bandwidth	Y: 0 to 5.75 MHz +5.0 dB/-3.0 dB	
S/N ratio	56 dB or more	
Y/C delay	15 ns or less	
K Factor (2T Pulse)	1% or less	
Output SCH phase	Based upon RS-170A/CCIR R.624-3	
<b>Digital-Audio Performance</b>		
Sampling frequency	48 kHz (synchronized with video)	
Quantization	HDCAM-SR: 24 bits/sample HDCAM*: 20 bits/sample	
Wow & flutter	Below measurable level	
Headroom	20/18/16/12 dB selectable	
<b>Analog Audio-Output Performance</b>		
D/A quantization	24 bits/sample	
Frequency response	20 Hz to 20 kHz, +0.5 dB/-1.0 dB (0 dB at 1 kHz)	
Dynamic range	More than 100 dB (At 1 dB at 1 kHz)	
Distortion	Less than 0.05% (At 1 kHz, reference level)	
Crosstalk	Less than -80 dB (At 1 kHz, between any two channels)	
De-emphasis	T1 = 50 μs, T2 = 15 μs (auto on/off)	
<b>Supplied Accessories</b>		
	Operation manual, installation manual	

\*The SRW-5000 does not support HDCAM recording.

\*\*HDCAM and Digital Betacam playback only.

# Optional Accessories



HKSR-5001,  
Format-Converter Board



BCT-6SR/33SR/40SR,  
BCT-64SRL/94SRL/124SRL,  
HDCAM-SR Video Cassette Tapes



HKSR-5002,  
Digital BETACAM Processor Board



BCT-6HD/12HD/22HD/40HD,  
BCT-34HDL/64HDL/94HDL/124HDL,  
HDCAM Cassette Tapes  
(For SRW-5500)

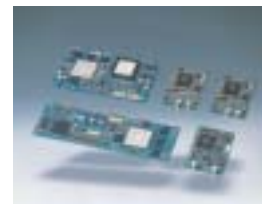

HKSR-5003,  
RGB Processor Boards



BCT-HD12CL,  
Video Head Cleaning Cassette



RMM-110,  
Rack-Mount Kit



HKDV-900,  
HD Digital Video Controller

# SONY

©2005 Sony Corporation. All rights reserved.  
Reproduction in whole or in part without written permission is prohibited.  
Features and specifications are subject to change without notice.  
All non-metric weights and measurements are approximate.  
23.98P, 24P, 25P, 29.97P, and 30P are used as generic names in this literature for the industry standard 23.98PsF, 24PsF, 25PsF, 29.97PsF, and 30PsF (Progressive Segmented Frames), respectively.  
Sony is a registered trademark of Sony Corporation.  
HDCAM-SR, HDCAM, BETACAM, CineAlta, Dynamic Tracking, and Memory Stick are trademarks of Sony Corporation.  
All other trademarks are the property of their respective owners.



---

Distributed by